

# THERMOSTATIC MIXING VALVES SERIES 61C – 62C – 61CM



## MAIN FEATURES

- Available with male and female connections
- 2 ranges of adjustment (32-50 °C / 42-60 °C)
- 4 setting positions
- In accordance with following standards:
  - UNI 9753/90 "Control valves for heating systems"
  - BSI 1415 British standards (Anti-scalding safety)

## DESCRIPTION

The thermostatic mixing valves **Aquamix Series 61C, 62C and 61CM** are offered in versions with male and female connections as well as 4 setting positions.

The valve body is made of brass, chrome-plated on both inside and outside; moreover an inner teflon coating is provided in order to reduce scaling caused by hard water. Each valve is provided with two mesh strainers which, when inserted inside the hot water (+) and cold water (-) ports avoid depositing of coarse particles thereby protecting valve operation.

## APPLICATION

The **Aquamix** valves are used in domestic hot water distribution mains in order to keep a constant temperature of the mixed water against variation in the temperature of the hot water coming from the water heater, in accordance with Italian Decree DPR 412/93 which specifies the compulsory requirement to distribute domestic hot water with a maximum temperature of 48 °C (tolerance + 5 °C). The setting ranges of valves **Series 61C, 62C and 61CM** allow direct mixing of hot water produced in the water heater (instantaneous or storage type) with cold water from the water main (to the water user at 36 - 38 °C) or obtaining higher values when used as premixer (42 - 50 °C) with consequent final mixing at the domestic water taps.

## OPERATION

Operation is automatic and takes place through a heat-sensitive element inserted in the valve body which, upon coming into contact with the mixed water, either expands or contracts, thus regulating the inlet, with proportional action, of hot and cold water from the side ports in relation to the set value.

If there is accidental failure of the cold water, the valve is provided with a thermal stop device which promptly intervenes to close the disc in order to prevent hot water from entering. Thus it is not possible to emit unmixed water with consequent risk of scalds, and therefore the valve meets requirements of the British Standards.

See chart for the hydraulic characteristics of flow rate and pressure drops of the valves.

## SETTING

The valve setting, i.e. setting of the temperature of the mixed water, is performed by manually turning the graduated handwheel so that the number printed on the handwheel coincides with the reference mark embossed on the valve body.

The numbers printed on the handwheel correspond to the temperatures indicated in **(Table 1)**. The valve is factory-set by using hot water at 70 °C and mains water at 15 °C. Variation in temperature of the water in the primary circuit causes a deviation (\* 2 °C) to the set values **(Table 2)**. Likewise a variation in pressure between P1 and P2 **(See installation diagrams)** exceeding 2 bar could cause differences; hence it is recommended to provide the circuit with a balancing valve (STAND type) at the cold water inlet port so as to create the same drop in pressure as occurs when the water flows through the heat exchanger.



### 61C

Thermostatic mixing valve with 4 setting positions. Setting range 32° - 50°C. Anti-scalding safety.

Part No.	Size	Kvs	Weight (g)
<b>6109C12</b>	1/2"F	1.5	630
<b>6110C34</b>	3/4"F	1.9	550
<b>6111C1</b>	1"F	2.1	650



### 62C

Thermostatic mixing valve with 4 setting positions. Setting range 42° - 60°C. Anti-scalding safety.

Part No.	Size	Kvs	Weight (g)
<b>6209C12</b>	1/2"F	1.5	630
<b>6210C34</b>	3/4"F	1.9	550
<b>6211C1</b>	1"F	2.1	650



### 61CM

Thermostatic mixing valve with male tailpieces. 4 setting positions. Setting range 32° - 50 °C. Anti-scalding safety.

Part No.	Size	Kvs	Weight (g)
<b>61CM12</b>	1/2"M	1.5	710
<b>61CM34</b>	3/4"M	1.9	640
<b>61CM1</b>	1"M	2.1	730

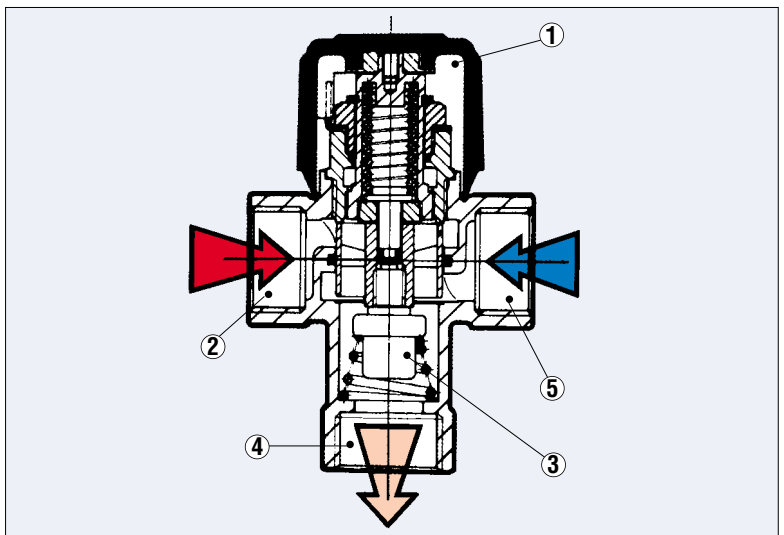

### Details

- 1) Setting handwheel
- 2) Hot water inlet port (+)
- 3) Thermostatic element
- 4) Mixed water outlet port (mix)
- 5) Cold water inlet port (-)

In order to prevent tampering, the handwheel can be locked in the required setting position as shown in **Pictures 1-2-3**.

The reliability of the thermostatic mixing valves **Aquamix Series 61C, 62C and 61CM** is ensured by 100% testing of the production.

## INSTALLATION

Choice of the thermostatic mixing valves **Aquamix Series 61C, 62C and 61CM** depends on the SIZE of the connecting piping. The valve can be installed on iron pipes (**Series 61C and 62C**), copper and plastic pipes (**Series 61CM**) in any position (vertical or horizontal).

The valves are designed for periodic maintenance of the internal components in order to remove any scaling without use of solvents and without scratching the metal surfaces. The three ways should be shut off before maintenance. This type of maintenance could be avoided by installing a water softener before the hot water inlet.

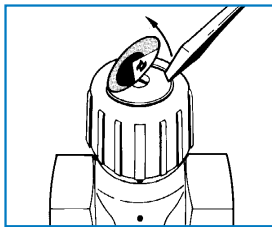

**Pic. 1** Remove the label using a screw driver.

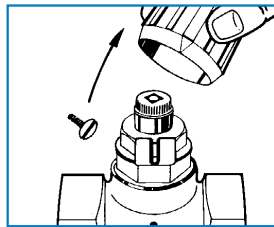

**Pic. 2** Back-off the stop screw and lift out the handwheel being careful not to turn the control rod.

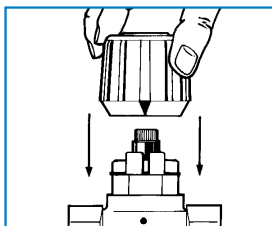

**Pic. 3** Refit the handwheel so that the V reference corresponds to the embossed mark on the valve body. The handwheel is locked in this position.

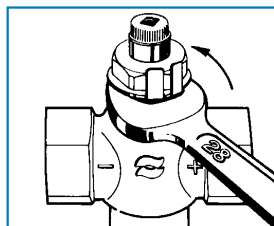

**Pic. 4** Using a 28 mm open-ended spanner, unscrew the valve cover and take out the thermostatic element - spring - disc assembly. Clean with water, then reassemble.

**Tab.1**

Type	1	2	3	4
61C-61CM	32°	38°	44°	50°
62C	42°	48°	54°	60°

**Tab.2**

Water, primary circuit	Setting positions			
°C	1	2	3	4
50	30	36	42	48
60	31	37	43	49
70	32	38	44	50
80	33	39	45	51
90	34	40	46	52

### TECHNICAL CHARACTERISTICS

Max. temperature, primary circuit 100 °C

Max. operating pressure 10 bar

Max. differential pressure 2 bar

N° of setting positions 4

Anti-scald safety BSI 1415

Liquids which can be used Water

### DESIGN FEATURES

Valve body a) brass, chrome-plated on inside and outside  
b) internally coated with scale-preventing teflon

Thermostatic element Based on expansion of solid element

Springs Stainless steel

Plug Brass

## Installation diagrams, AQUAMIX valve

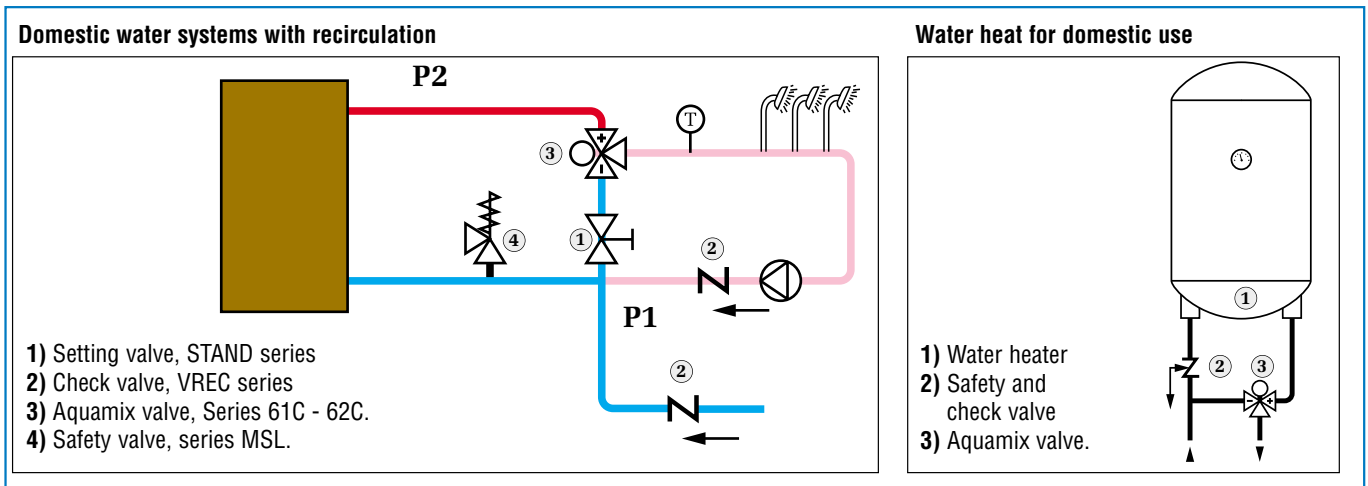

## Overall dimensions (mm)

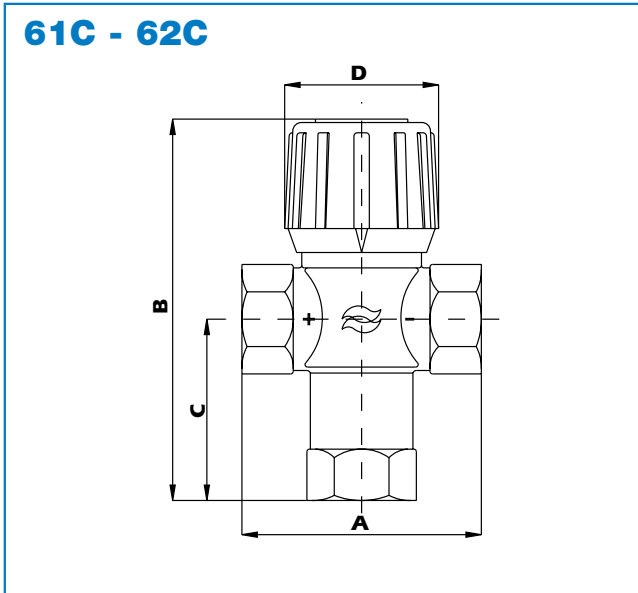

SIZE	A	B	C	D
1/2"	70	107	52	45
3/4"	70	107	52	45
1"	80	110	52	45

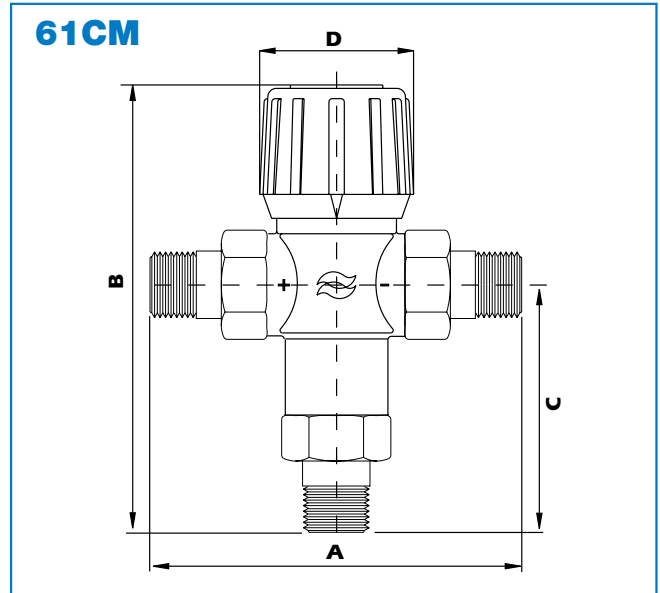

SIZE	A	B	C	D
1/2"	132	122	62	45
3/4"	136	123	66	45
1"	150	130	72	45

## Flow rate - Pressure drop chart

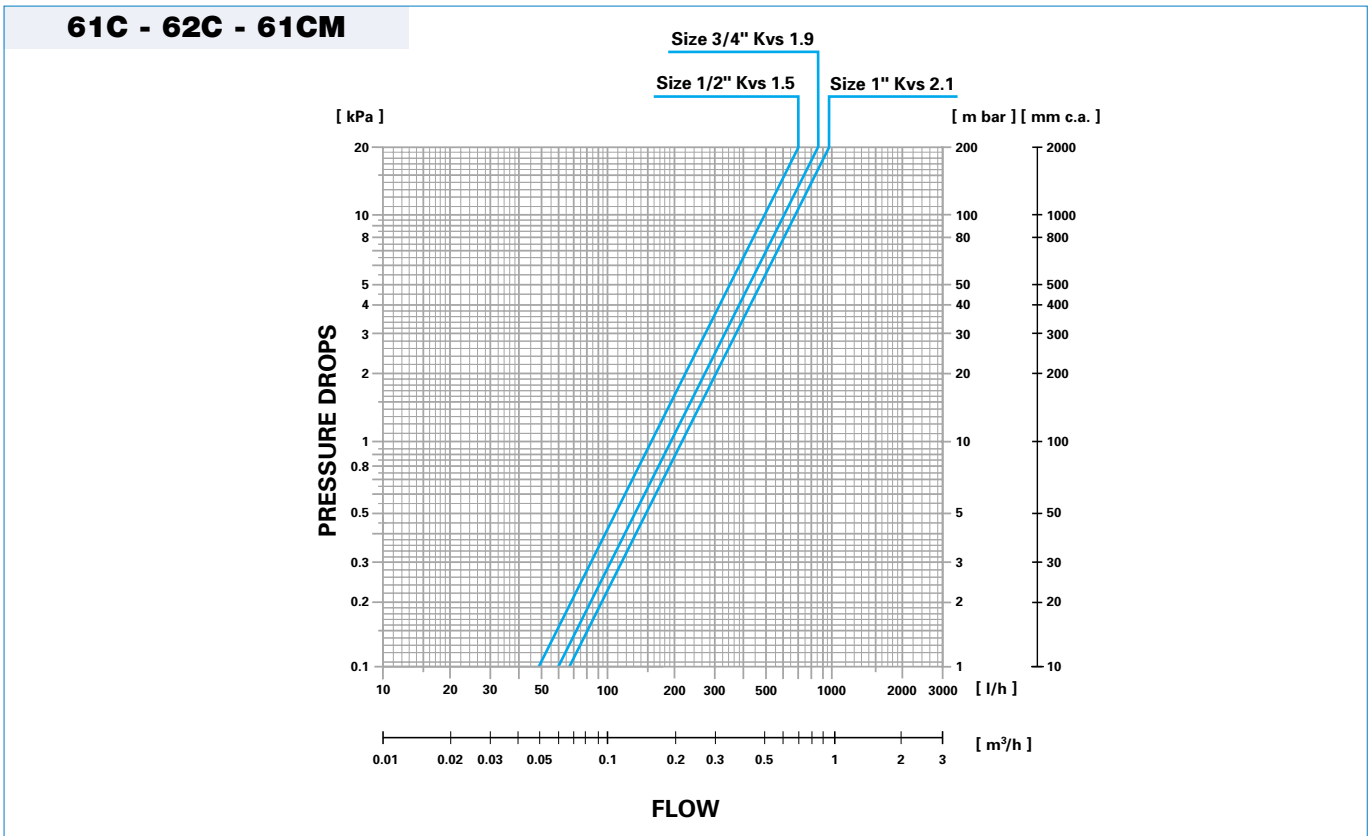

The descriptions and photographs contained in this product specification sheet are supplied by way of information only and are not binding. WATTS CAZZANIGA reserves the right to carry out any technical and design improvements to its products without prior notice.



WATTS Cazzaniga S.p.A.  
 Via Parco, snc - 20046 Biassono (MI) - Italy  
 Phone ++39 039 49.86.1 - Fax ++ 39 039 49.86.285  
 www.wattseurope.com e-mail: info@wattscazzaniga.it